

ECONV-128I-500Hz

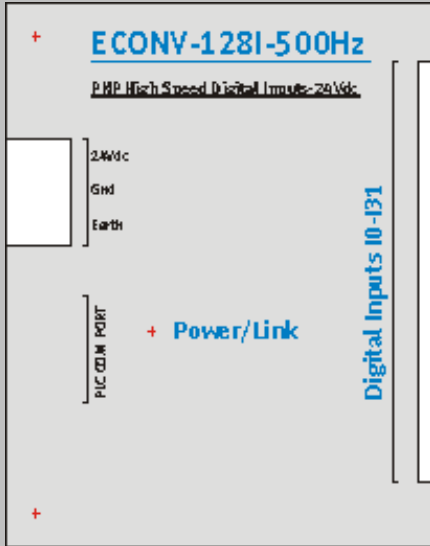

ECONV-128I-500Hz

User Reference 1.4

Fast Digital PNP Input -24Vdc

PRELIMINARY

Description: ECONV-128I-500Hz
Publication : **Rev. 1.4 (19/8/8)**
Author: www.festosara.com.ar
Argentina

The information inside this manual could be modified without previous notification.
Information furnished in this manual is believed to be accurate and reliable. However, no responsibility is assumed for its use, or for any infringements of patents or other rights of third parties.

User Reference v1.4

ECONV-128I-500Hz, fast digital PNP input – 24Vdc

About this Manual

Please read through this manual carefully before beginning with the installation. The ECONV-128I-500Hz module is designed to be a low cost, versatile industrial module that is quick and easy to install.

Installation Instructions

- When installing the ECONV-128I-500Hz, take the environmental conditions into account under which the device normally operates.
- Do not install the ECONV-128I-500Hz In areas which are subject to excessive dust, oil mist, conductive dust or corrosive gas
- Do not install directly in areas which are subject to shock or vibrations
- Do not install in areas which are subject to high temperatures, direct sun irradiation, humidity or rain
- Do not install near high-voltage devices or lines

Caution

- Ensure that no wire pieces, fillings or shavings fall into the device when holes are drilled or wires connected.
- Do not mount the ECONV-128I-500Hz directly above a heat-generating source, such as a heater, a current transformer or a high-wattage resistor.
- The communication use COMM PORT interface, via Command interpreter of the PLC. The communication and extension interface of the IPC FEC-Standard operate with a TTL level (5 V). Only use the respective accessories offered (FEC KSD4).
- Check the power supply and earthing connections and the inputs connections before switching then power on.
- Make sure that the power is **switched off** before replacing cables.

Features:

- **128 fast digital Input for FEC Compact and Standard.**
- **All inputs are Opto isolated.**
- **Single power supply of 24Vcc.**
- **From 0.5Hz up to 500Hz frequency counter on each input.**

This module is capable to measure the frequency on 128 digital inputs up to 500 Hz and write these values directly on FEC Compact or FEC Standard using the communication TTL port of the PLC. Each frequency measure has a resolution of 0.5Hz and is assigned from FW300 to FW427.

The value of the frequency input is multiply by 2 and then is written in the corresponding FW.

Example:

If we have a frequency of 411 Hz in the digital input 0 then the ECONV-128I-500Hz write a value of 822 in FW300.

Digital input 0=411Hz >>>> FW300=411*2=822

Test Status of ECONV-128I-500Hz:

Then ECONV-128I-500Hz toggle the value of FW428 between 0 and 1 every time then Fw300 to Fw427 are updated. Using it, is possible check the communication is working OK. The PLC should check is the FW428 is toggle between 0 and 1, so it confirm the communication with ECONV-128i-500Hz is OK.

Power/Link Led status:

If link between PLC and ECONV-128i_500Hz is OK then POWER/LINK flashes-green, else it toggle RED-OFF states.

Connector pin out assignments:

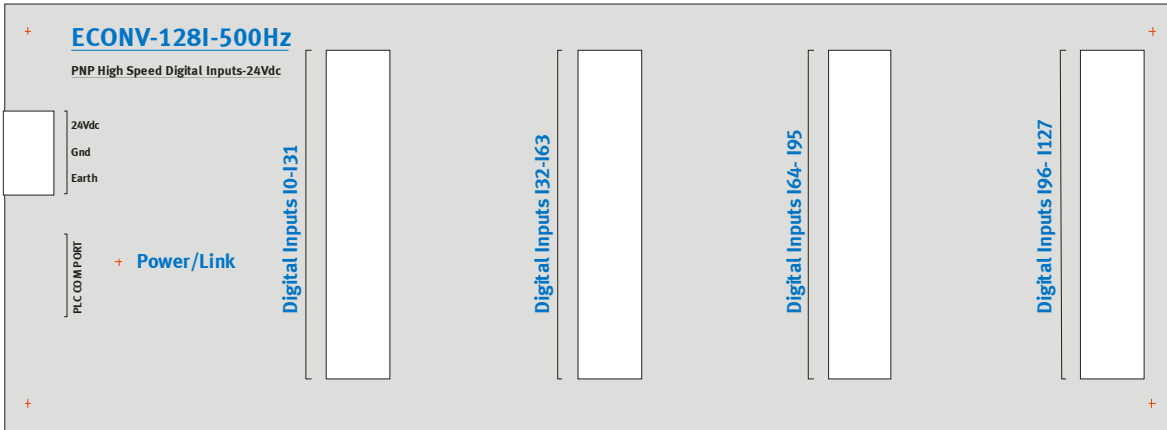

Power Connector:

The POWER CONNECTOR has 3 pins:

- Pin 1 24Vdc +/- 10%
- Pin 2 GND
- Pin 3 EARTH

DB37 Male Connector description:

Each pin in the DB37 has it assignment flag word as follow:

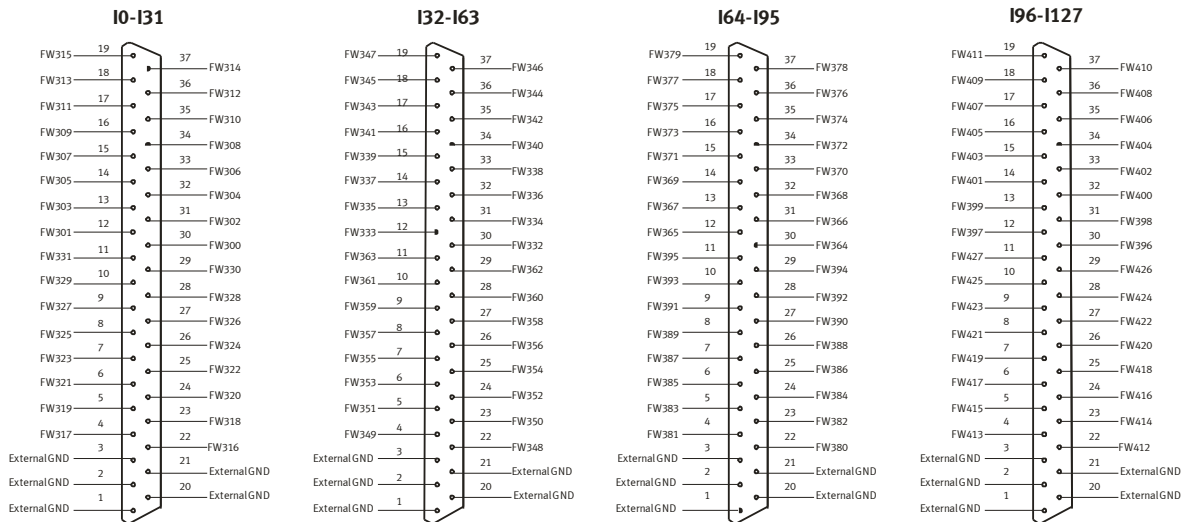

Note:

Each DB37 has it own External Ground, independently each other.

Example of connection:

In this example, an inductive sensor is connected to pin 3 of the first DB37, so FW311 is actualized with the frequency generated at this input pin.

Note that then External ground and External 24DVC in necessary to operate because each input is optoisolated.

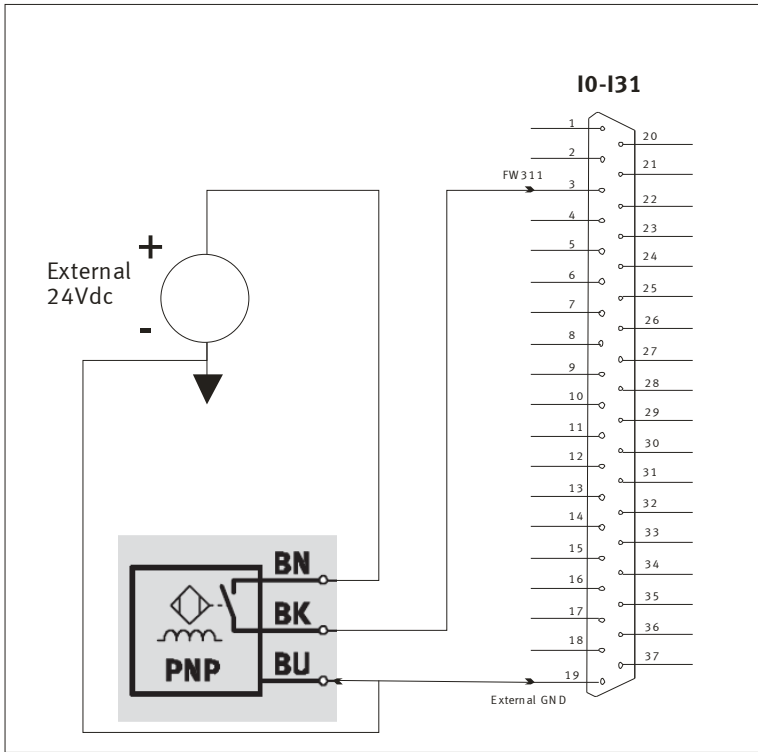

Note: The duty cycle of inputs must be between 25%-50%, that is:

$$\text{Time ON} \geq \text{Time Off} * 0.25$$

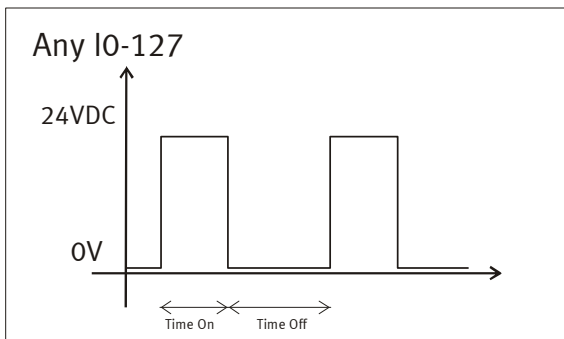

PLC COMM interface :

The Fec module has a serial PORT COMM interface via which the FEC modules can be connected to external world, for example with a remote expansion device. The FEC-COMM PORT interface works using TTL Levels (0-5V). In order to connect an ECONV-128I-500Hz as a remote expansion you require a FEC KSD4 cable. Since both station are connected via a TTL interface, this may only be implemented using an short cable , less than 30 cm. If cable is any longer, reliable operation of the connection is not guaranteed. The format of communication is 9600,8,n,1.

That is:

Bauds: 9600
Data: 8 bits
Parity: No
Stop Bits: 1
Flow Control: Nothing

that is de default speed of COMM PORT.

Please remember that the interface produce TTL signals and is NOT galvanically separated.

Pin assignment of COMM PORT interface:

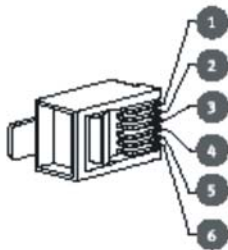

Pin no.	Signal name
1	+5 V
2	GND
3	TXD
4	RXD
5	CTS
6	RTS